

1.Components

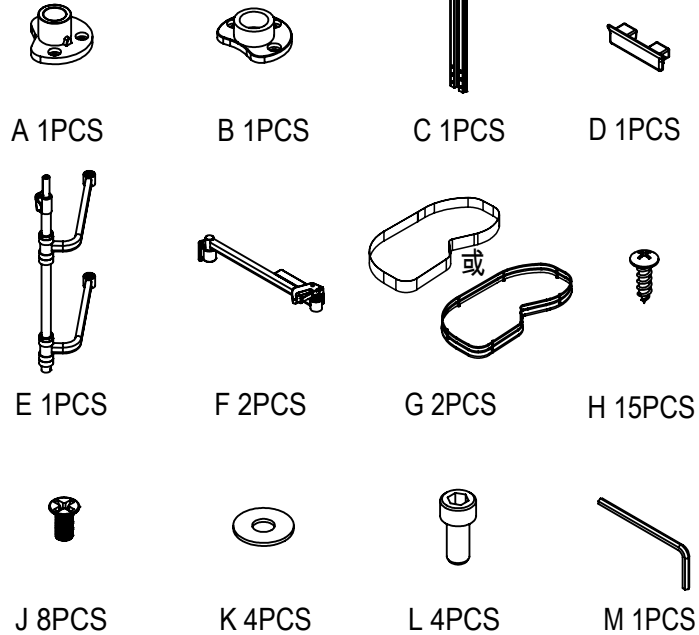

2.Cabinet Size

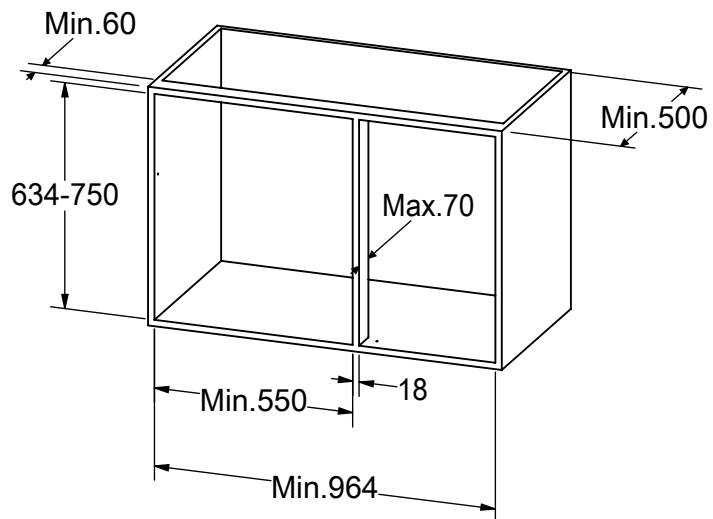

3.Fixing Steps

①

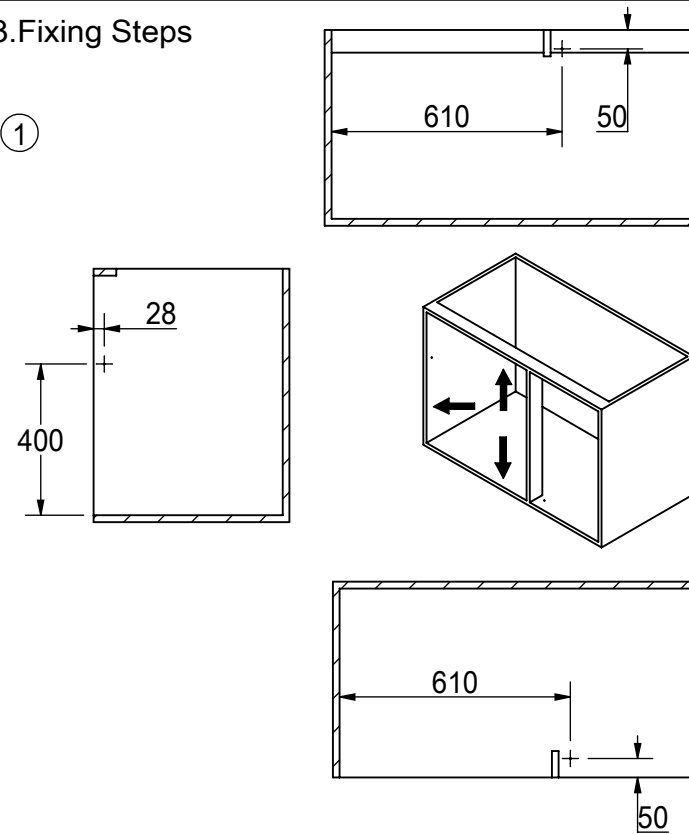

②

